



Designation: D2512 – 17

# Standard Test Method for Compatibility of Materials with Liquid Oxygen (Impact Sensitivity Threshold and Pass-Fail Techniques)<sup>1</sup>

This standard is issued under the fixed designation D2512; the number immediately following the designation indicates the year of original adoption or, in the case of revision, the year of last revision. A number in parentheses indicates the year of last reapproval. A superscript epsilon ( $\epsilon$ ) indicates an editorial change since the last revision or reapproval.

*This standard has been approved for use by agencies of the U.S. Department of Defense.*

## 1. Scope

1.1 This method<sup>2,3,4</sup> covers the determination of compatibility and relative sensitivity of materials with liquid oxygen under impact energy using the Army Ballistic Missile Agency (ABMA)-type impact tester. Materials that are impact-sensitive with liquid oxygen are generally also sensitive to reaction by other forms of energy in the presence of oxygen.

1.2 *This standard should be used to measure and describe the properties of materials, products, or assemblies in response to heat and flame under controlled laboratory conditions and should not be used to describe or appraise the fire hazard or fire risk of materials, products, or assemblies under actual fire conditions. However, results of this test may be used as elements of a fire risk assessment which takes into account all of the factors which are pertinent to an assessment of the fire hazard of a particular end use.*

1.3 *This standard does not purport to address all of the safety concerns, if any, associated with its use. It is the responsibility of the user of this standard to establish appropriate safety and health practices and determine the applicability of regulatory limitations prior to use.*

1.4 *This international standard was developed in accordance with internationally recognized principles on standardization established in the Decision on Principles for the Development of International Standards, Guides and Recommendations issued by the World Trade Organization Technical Barriers to Trade (TBT) Committee.*

<sup>1</sup> This test method is under the jurisdiction of ASTM Committee G04 on Compatibility and Sensitivity of Materials in Oxygen Enriched Atmospheres and is the direct responsibility of Subcommittee G04.01 on Test Methods.

Current edition approved July 1, 2017. Published July 2017. Originally approved in 1966. Last previous edition approved in 2002 as D2512 – 95 (2002)<sup>ε1</sup> which was withdrawn January 2017 and reinstated in July 2017. DOI: 10.1520/D2512-17.

<sup>2</sup> *NASA Handbook 8060. 1B, Ambient LOX Mechanical Impact Screening Test*, September 1981, pp. 4-53 through 4-71. "Oxygen Systems." George C. Marshall Space Flight Center, National Aeronautics and Space Administration. *Specification MSFC 106B*. September 1981.

<sup>3</sup> "Lubrication and Related Research and Test Method Development for Aviation Propulsion Systems." *Technical Report No. 59-726*. Wright Air Development Division, January 1960.

<sup>4</sup> "General Safety Precautions for Missile Liquid Propellants."

## 2. Referenced Documents

2.1 *ASTM Standards*:<sup>5</sup>

C145 Specification for Solid Load-Bearing Concrete Masonry Units (Withdrawn 1992)<sup>6</sup>

D1193 Specification for Reagent Water

2.2 *Military Standards*:

MIL-D-16791G Detergent, General Purpose (Liquid, Non-ionic)<sup>7</sup>

MIL-P-27401C Propellant Pressurizing Agent, Nitrogen<sup>7</sup>

MIL-PRF-25508F Propellant, Oxygen<sup>7</sup>

MIL-T-27602B Trichloroethylene, Oxygen Propellant Compatible<sup>8</sup>

MIL-C-81302D Cleaning Compound, Solvent, Trichlorotrifluorocarbon<sup>7</sup>

2.3 *ASTM Adjuncts*:

Type Impact Tester and Anvil Region Assembly, 38 Drawings

## 3. Summary of Test Method

3.1 A sample of the test material is placed in a specimen cup, precooled and covered with liquid oxygen, and placed in the cup holder located in the anvil region assembly of the impact tester. A precooled striker pin is then centered in the cup. The plummet is dropped from selected heights onto the pin, which transmits the energy to the test specimen. Observation for any reaction is made and the liquid oxygen impact sensitivity of the test material is noted. Drop tests are continued using a fresh specimen cup and striker pin for each drop, until

<sup>5</sup> For referenced ASTM standards, visit the ASTM website, [www.astm.org](http://www.astm.org), or contact ASTM Customer Service at [service@astm.org](mailto:service@astm.org). For *Annual Book of ASTM Standards* volume information, refer to the standard's Document Summary page on the ASTM website.

<sup>6</sup> The last approved version of this historical standard is referenced on [www.astm.org](http://www.astm.org).

<sup>7</sup> Available from Standardization Documents Order Desk, DODSSP, Bldg. 4, Section D, 700 Robbins Ave., Philadelphia, PA 19111-5098, <http://dodssp.daps.dla.mil>.

<sup>8</sup> Cancelled in 1983. Previously available from Standardization Documents Order Desk, DODSSP, Bldg. 4, Section D, 700 Robbins Ave., Philadelphia, PA 19111-5098, <http://dodssp.daps.dla.mil>.

the threshold valve is achieved. A series of drop tests are conducted at an energy level of 98 J (72 ft-lbf) or as specified for the pass-fail tests.

**4. Significance and Use**

4.1 When this test method is used to measure the threshold impact sensitivity of a material, a relative sensitivity assessment is obtained which permits the ranking of materials.

4.2 This test method may also be used for acceptance-testing materials for use in liquid oxygen systems. Twenty separate samples of the material submerged in liquid oxygen are subjected to 98 J (72 ft-lbf) or as specified. Impact energy delivered through a 12.7-mm (1/2-in.) diameter contact. More than one indication of sensitivity is cause for immediate rejection. A single explosion, flash, or other indication of sensitivity during the initial series of 20 tests requires that an additional 40 samples be tested without incident to ensure acceptability of the material.

4.3 The threshold values are determined by this test method at ambient pressure. The sensitivity of materials to mechanical impact is known to increase with increasing pressure. Since most liquid oxygen systems operate at pressures above ambient condition, some consideration should be given to increased sensitivity and reactivity of materials at higher pressure when selecting materials for use in pressurized system.

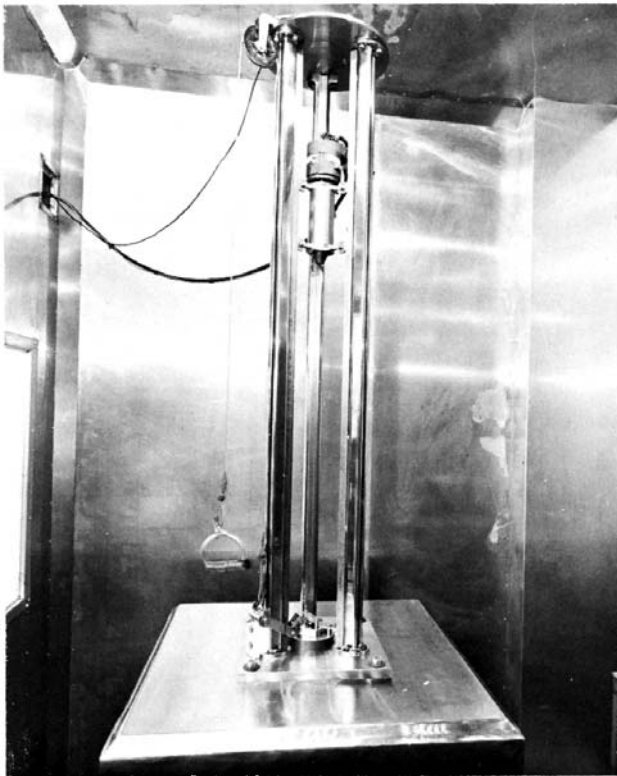

FIG. 1 ABMA-Type Impact Tester

**5. Apparatus**

5.1 *ABMA-Type Impact Tester*<sup>9</sup> (Fig. 1, See ADJD2512), for determining the sensitivity of materials to liquid oxygen with impact energy. Fig. 2 shows the schematic diagram of the typical power supply. The tester consists of the following parts:

5.1.1 *Three Guide Tracks*, capable of maintaining accurate vertical alignment under repeated shock conditions.

5.1.2 *Plummet*, with a weight of  $9.072 \pm 0.023$  kg ( $20 \pm 0.05$  lbs).

5.1.3 *Safety Catch*, operated by a solenoid, and designed to hold the plummet near the base of the magnet. It is used to support the plummet in the event of a power failure.

5.1.4 *Electromagnet*, for supporting or releasing the plummet. The electromagnet is designed to hold 9.072 kg (20 lbs) of weight with a minimum amount of electrical energy.

5.1.5 *Base*—The base of the tester is composed of the following: a rigid 0.61- by 0.61-m (2- by 2- by 2-ft) (min) reinforced concrete block (concrete conforming to Specification C145), a 3.2-mm (1/8-in.) stainless steel sheet, and a 25-mm (1-in.) thick stainless steel base plate. Four stainless steel foundation bolts protruding from the concrete block are used to fasten the plate and sheet to the smooth surface of the concrete block with stainless steel nuts.

NOTE 1—Where not otherwise indicated, stainless steel shall be of the AISI 300 series.

5.1.6 *Anvil Plate* (Fig. 3), made from a 51-mm (2-in.) thick Type 440B heat-treated steel plate, (56 to 58 HRC) that is centered and rests on the base plate. It in turn centers the specimen cup holder.

<sup>9</sup> Detailed drawings for the ABMA-Type Impact Tester and Anvil Region Assembly are available from ASTM International Headquarters. Order Adjunct ADJD2512.

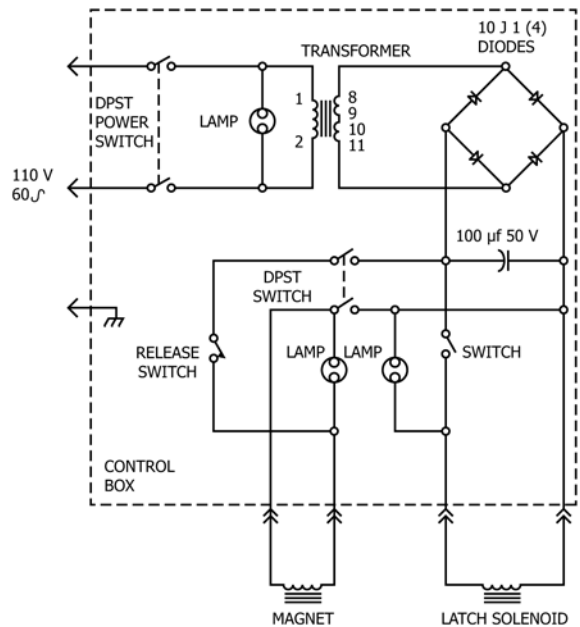

FIG. 2 Schematic Diagram of Power Supply

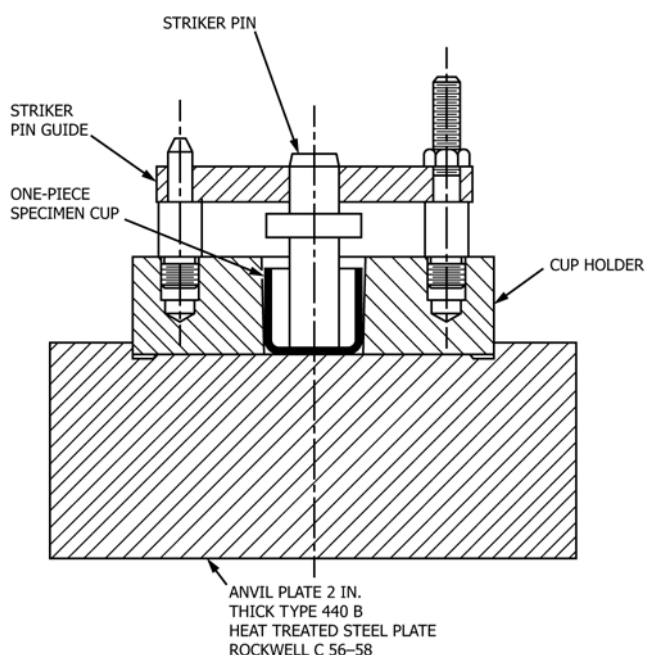

FIG. 3 Anvil Region Assembly

5.1.10 *Specimen Cup Holder*, consisting of a 25-mm (1-in.) thick stainless steel block centered on the anvil plate. This holder has two protruding spacers which align the striker pin guide, and in turn the striker pin, with the nose of the plummet, thus ensuring a direct hit by the nose of the plummet on the striker pin in the specimen cup.

5.2 *Test Cell*—The impact tester shall be housed in a test cell containing a concrete floor. Walls shall be constructed of reinforced concrete or metal to provide protection from explosion or fire hazards. The cell shall be provided with a shatterproof observation window, and shall be darkened sufficiently to permit observation of flashes. The operator shall be located in a darkened area. Continuous ventilation shall provide fresh air to the test cell. Construction of the cell shall be directed at providing a facility that can be maintained economically at a high level of good housekeeping. The test cell shall be cleaned periodically to ensure cleanliness of sample and equipment.

5.3 *Freezing Box*, as illustrated in Fig. 8.

5.4 *Auxiliary Equipment*—The auxiliary equipment shall consist of forceps for handling the specimen cups and striker pins, stainless steel spatulas, liquid oxygen handling equipment such as stainless steel Dewar flasks, liquid oxygen protective gloves, lintless laboratory coat, eye protection equipment, and liquid oxygen storage containers. Special handling equipment shall include striker pin holders (Fig. 9), specimen cup trays, covered storage container for specimen cups and striker pins, and a vapor-phase degreaser. The following items are also recommended: microburet, control panel with switches to activate the safety catch and electromagnet, stereomicroscope, micrometer depth gage with leveling blocks, press punch cutter for preparation of plastic specimens, oven, and refrigerator. For checking surface roughness of striker pins and specimen cups, a set of visual roughness comparison standards<sup>10</sup> or a surface roughness measuring instrument shall be required. Timing instrumentation shall be required to measure the drop time of the plummet. A suitable free-fall timing circuit is illustrated in Fig. 10.

5.1.7 *Striker Pin*—The striker pins shall be machined from AMS 5643D stainless steel, heat condition H-900 (Fig. 4).

5.1.8 *Striker Pin Guide*.

5.1.9 *Specimen Cups*—One- and two-piece specimen cups shall be used. The one-piece specimen cup (Fig. 5) shall be used for liquid and solid test materials. When testing hard samples that are sometimes capable of initiating reactions with the aluminum cup, expendable Type 347 stainless steel disks 17.5 mm (1<sup>1</sup>/<sub>16</sub> in.) in diameter by 1.6 mm (1<sup>1</sup>/<sub>16</sub> in.) thick shall be placed in the bottom of the cup. The two-piece cup (Fig. 6) shall be used for testing semisolid materials; a one-piece insert cup (Fig. 7) may also be used. The recess of either of these permits use of a 1.27-mm (0.050-in.) thick sample.

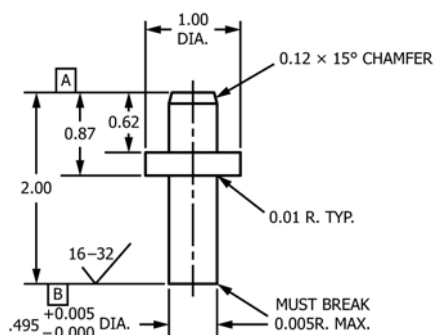

- NOTE 1—Break sharp edges approximately 0.015.
- NOTE 2—Machine all surfaces 32 rms except as noted.
- NOTE 3—Material: stainless steel AMS 5643 D.
- NOTE 4—Heat treatment: H-900 to obtain Rc 43 to 44.
- NOTE 5—Finish: electropolish after heat treatment.
- NOTE 6—Surfaces A and B should be parallel and perpendicular to the center line within 0.001TIR and 16-32 rms along a radius.

FIG. 4 Striker Pin

## 6. Reagents and Materials

6.1 *Alkaline Cleaner*, for striker pins and stainless steel inserts, consisting of a solution of 15 g of sodium hydroxide (NaOH), 15 g of trisodium phosphate (Na<sub>3</sub>PO<sub>4</sub>), and 1 L of distilled or deionized water.

6.2 *Alkaline Cleaner*, for cups; a nonetch-type solution such as Enthone NE<sup>11</sup> or equivalent shall be used.

6.3 *Aqua Regia*—Mix 18 parts of concentrated HNO<sub>3</sub> (sp gr 1.42) with 82 parts of concentrated hydrochloric acid (HCl, sp gr 1.19) by volume.

6.4 *Deionized Water*, conforming to Specification D1193.

6.5 *Detergent, General-Purpose (Liquid, Nonionic)*, conforming to MIL-D-16791G.

<sup>10</sup> American National Standard B46.1-1962. Surface Texture standards may be used.

<sup>11</sup> Available from Enthone, Inc., a division of American Smelting and Refining Co., Box 1900, New Haven, CT 06508.